



Characteristics

Nominal voltage	12V (6 cells per unit)	
Nominal capacity at 10 hours rate/10.8V (25°C)	200Ah	
Capacity (25°C)	20 Hours rate/10.8V	212Ah
	5 Hours rate/10.8V	170Ah
Terminal type	M8	
Torque	12.3±2.5N.m	
Approx. internal resistance (25°C)	3.5mΩ	
Dimensions	Length	522±2mm (20.55inch)
	Width	238±2mm (9.37inch)
	Height	218±2mm (8.58inch)
	Total height (T14)	222±2mm (8.74inch)
Design Life (stand-by)	JIS at 25°C	10 years
	Eurobat at 20°C	10/12 years
Weight	59.50kg (131.20lbs)±3%	
Nominal operating temperature	25°C±3 (77±5°F)	
Operating temperature range	Discharge	-15°C~50°C (5°F~122°F)
	Charge	-10°C~50°C (14°F~122°F)
	Storage	-20°C~50°C (-4°F~122°F)
Float charging voltage at 25°C	13.5V~13.8V	
Cyclic charging voltage at 25°C	14.5V~15.0V	
Temperature compensation	Float charge	-18 mV/°C/Block
	Cycle charge	-30 mV/°C/Block
Max. charging current (A)	60A	
Max. discharge current for 5 seconds	1400A	
Self discharge rate (25°C)	≤3%/month	
Battery container ABS UL94-HB	V-0 optional	

Overview

Leaftron LTL series batteries are designed with state-of-the-art AGM (absorbent glass mat) technology, high-performance plates and electrolyte. With excellent value and characteristics, this range is suitable for all general purpose applications.

Dimensions & Terminal Type (mm)

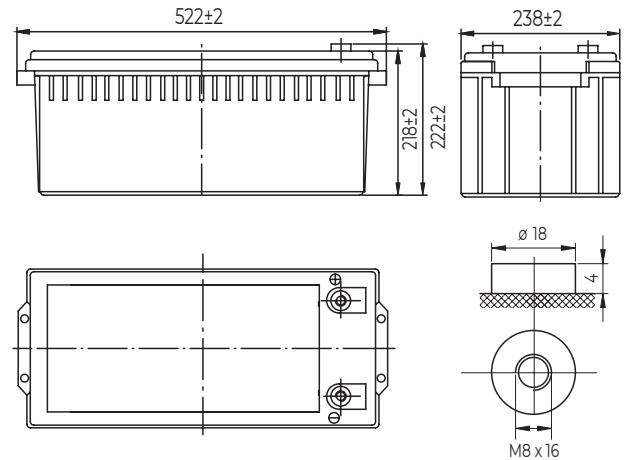

Certification & Compliances



Compliant to: EUROBAT, RoHS, WEEE's and Reach.
Manufactured according to IEC 60896-21 / 22

Construction

Component	Positive Plate	Negative plate	Container	Separator	Electrolyte	Safety valve	Terminal
Raw material	Lead dioxide	Lead	ABS (V-0 opt.)	AGM	Sulfuric Acid	Rubber	Copper

Constant current discharge characteristics at 25°C

(Ampere/battery)

F.V/Time	15min	30min	60min	2h	3h	4h	5h	6h	8h	10h	20h
9.60V	336	201	124	73.1	52.6	42.0	35.9	31.2	24.7	20.4	10.8
9.90V	328	197	122	72.6	52.3	41.8	35.7	31.0	24.5	20.3	10.8
10.2V	316	191	119	72.0	52.0	41.5	35.4	30.8	24.4	20.3	10.7
10.5V	305	186	115	70.9	51.6	41.2	35.2	30.6	24.2	20.1	10.7
10.8V	289	179	111	69.1	50.1	40.0	34.1	29.7	23.5	20.0	10.6

Constant power discharge characteristics at 25°C

(Watts/battery)

F.V/Time	15min	30min	60min	2h	3h	4h	5h	6h	8h	10h	20h
9.60V	3689	2255	1409	846	619	494	424	369	293	243	129
9.90V	3601	2210	1388	841	615	491	422	367	292	243	129
10.2V	3468	2142	1353	834	611	488	419	364	290	242	129
10.5V	3350	2091	1310	821	607	485	416	362	287	240	128
10.8V	3173	2014	1268	800	589	470	404	351	279	239	127

LTL12-200 (12V200AH)

LTL SERIES Long Life Standby

Discharge characteristics (25°C)

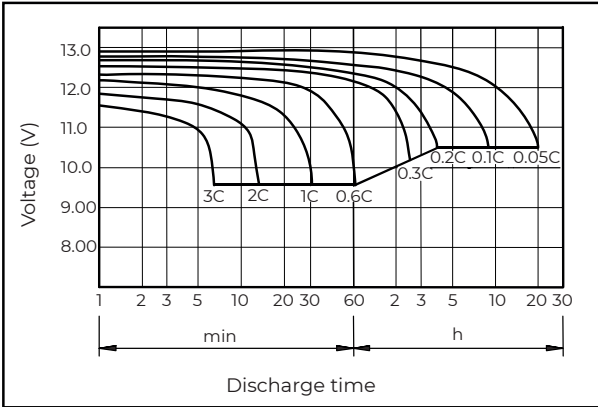

Charging characteristics (25°C)

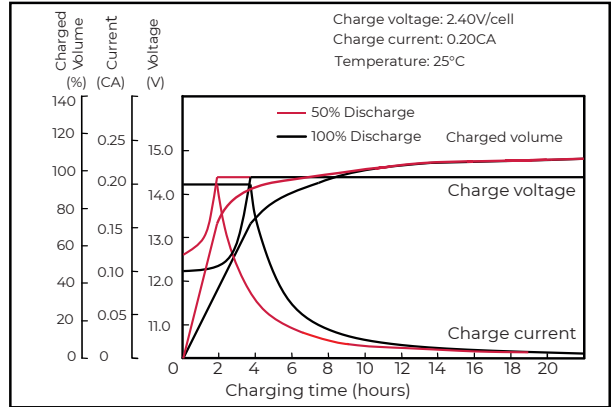

Temperature effects on capacity

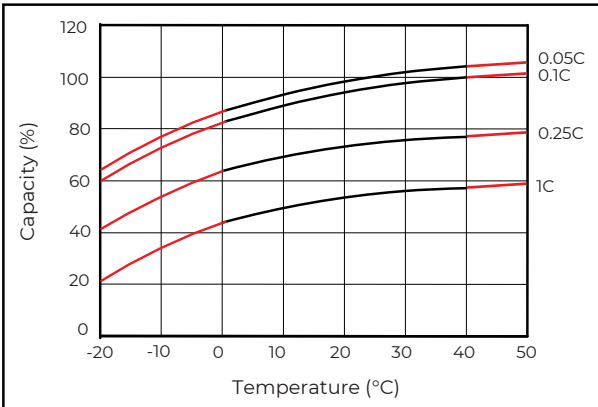

Self-discharge characteristics

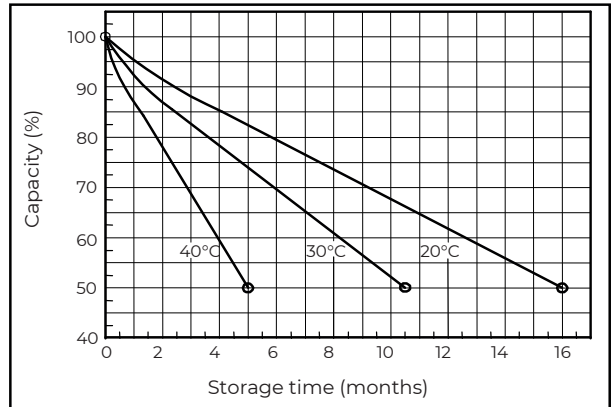

Floating life on temperature

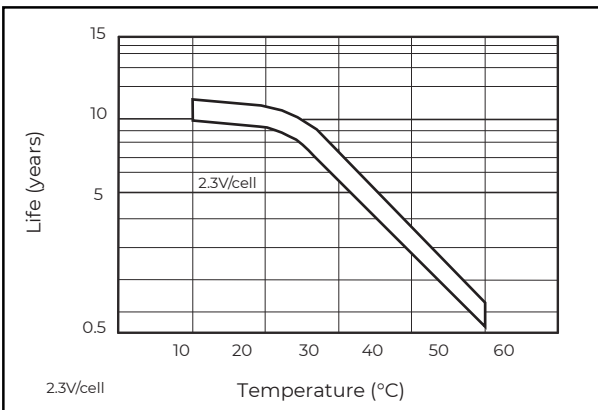

Cycle life on D.O.D (25°C)

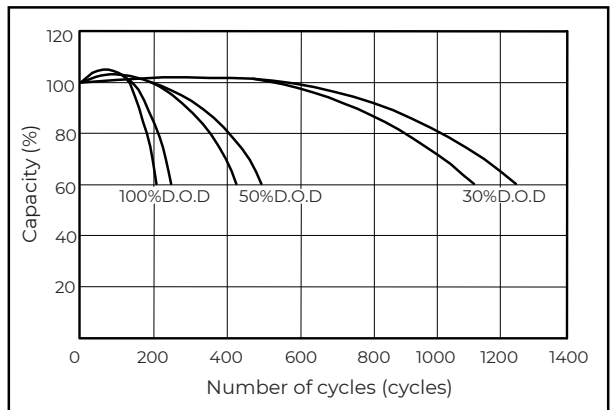

Relationship for OCV and capacity (25°C)

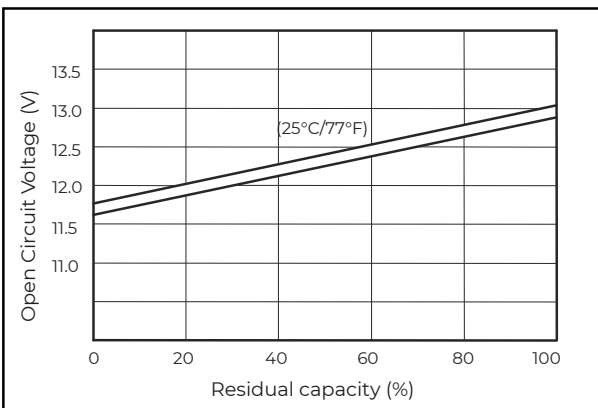

Charging voltage VS temperature

